

Technical data sheet for
VEE RAY FILTAMAX

EF30, EF35, EF40

- Mobility and space saving features
- Powerful reversible 1/3 HP pump
- Full stainless steel construction
- Reusable filter bag
- Upgrade kit to carbon pad filtering
- Easy clean
- Easy service

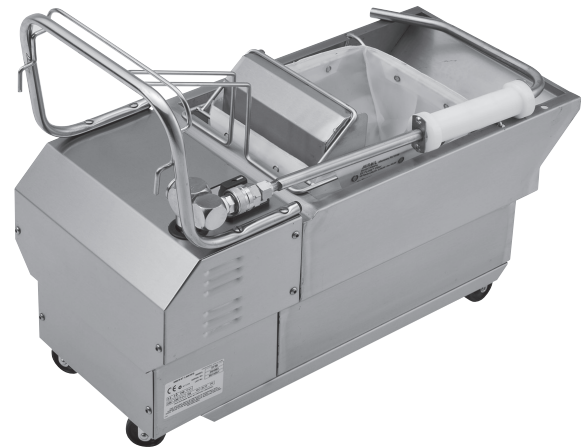

EF35

Overall Construction

- Full stainless steel construction
- Mounted on two fixed and two swivel castors
- 1/3 HP motor, reversible, heavy duty pump
- Heavy duty motor switch
- Rigid return delivery tube for safe, efficient, return of oil and shortening to fryer tank
- Reusable 'easy clean' filter bags, with upgrade kit to carbon pad filtering available
- Heavy duty stainless steel handle
- Cord storage
- Heavy duty heat resistant handle fitted to oil delivery tube

Controls

- Off/Forward/Reverse pump control

Cleaning and Servicing

- Open stainless steel pan for easy clean
- Easy clean stainless steel exterior

Technical data sheet for VEE RAY FILTAMAX

Specifications

Pump

1/3 HP single phase reversible pump

Electrical requirements

220 - 240 V.a.c., 50/60 Hz, 1 P+N+E, 3.2A
110 - 120 V.a.c., 50/60 Hz, 1 P+N+E, 6.4A

Electrical connection

62mm from RH side, 365mm from rear, and 440mm from floor
3 pin 10A plug cordset fitted

Filtering capacity

EF30 20 litres
EF35 30 litres
EF40 32 litres

Fryer compatibility

EF30 GT45/E
GT46/E
EF35 E43/E
E44/E
EF40 GT60/E
GT60-HPO/E

Under fryer storage

EF30 GT45/E
GT46/E
EF35 N/A
EF40 GT60/E
GT60-HPO/E

Dimensions

EF30
Width 324mm
Depth 683mm
Height 562mm

EF35
Width 324mm
Depth 735mm
Height 562mm

EF40
Width 474mm
Depth 683mm
Height 562mm

Packing data

EF30
0.28m³
52kgs

EF35
0.28m³
53kgs

EF40
0.28m³
56kgs

Options at extra cost

Additional filter bags
Carbon pad upgrade kit (Part No. 025669)
Flexible hose with stay cool handle (Part No. 020417)
Drain adaptor kit (Part No. 024705) and drain extension kit (Part No. 024710) available for using EF40 for combined 450mm + 600mm wide Blue Seal fryer filtering applications.

EF30

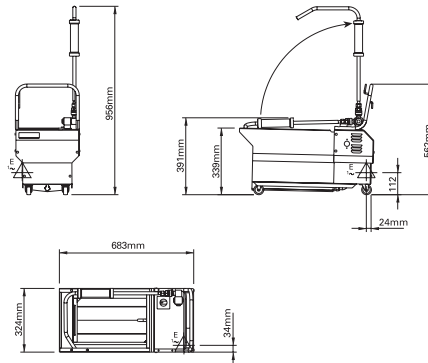

EF35

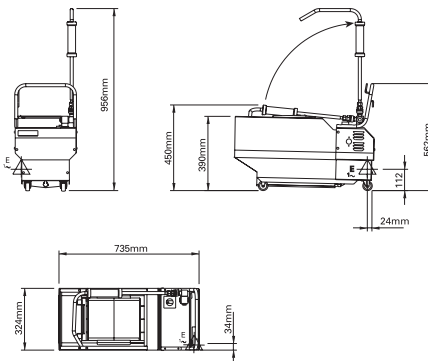

EF40

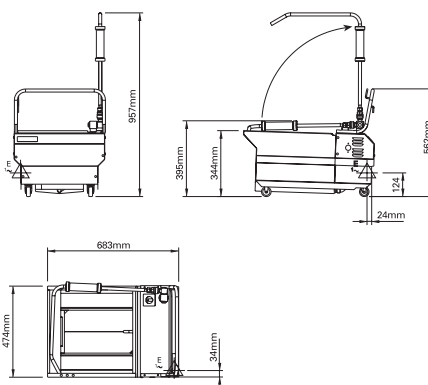

BLUE SEAL
EVOLUTIONSERIES

VEERAY

MOFFAT

Australia
www.moffat.com.au
New Zealand
www.moffat.co.nz
www.bluesealevolution.com

Australia
Moffat Pty Limited

Victoria/Tasmania
740 Springvale Road
Mulgrave, Victoria 3170
Telephone 03-9518 3888
Facsimile 03-9518 3833
vsales@moffat.com.au

New South Wales
Telephone 02-8833 4111
nswsales@moffat.com.au

South Australia
Telephone 03-9518 3888
vsales@moffat.com.au

Queensland
Telephone 07-3630 8600
qldsales@moffat.com.au

Western Australia
Telephone 08-9202 6820
bgarcia@moffat.com.au

New Zealand
Moffat Limited

Christchurch
16 Osborne Street
Christchurch 8011
Telephone 03-389 1007
Facsimile 03-389 1276
sales@moffat.co.nz

Auckland
Telephone 09-574 3150
sales@moffat.co.nz

ISO 9001
Quality Management Standard

Designed and manufactured by

MOFFAT

ISO9001
All Blue Seal products are designed and manufactured by Moffat using the internationally recognised ISO9001 quality management system, covering design, manufacture and final inspection, ensuring consistent high quality at all times.

In line with policy to continually develop and improve its products, Moffat Limited reserves the right to change specifications and design without notice.

Printed in China
© Copyright Moffat Ltd
Moffat/4825/BH/2.5M/12.06

